

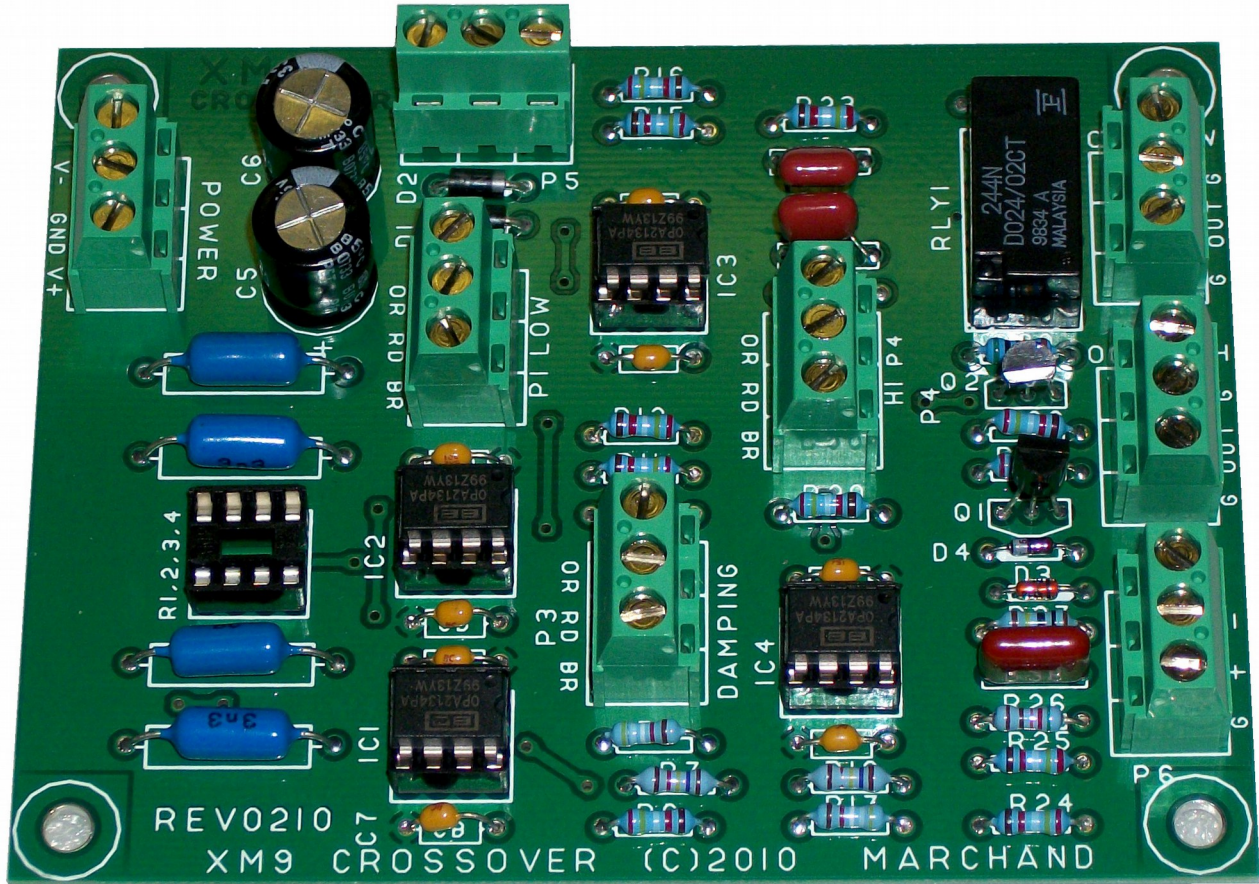

Marchand Electronics Inc.
Electronic Crossover Circuit Board
Model XM9



Users Manual
Assembly Manual

Marchand Electronics Inc. Rochester NY
(c) 1990....2015 Marchand Electronics Incorporated
Last updated 5 March 2015
www.marchandelec.com

XM9 ELECTRONIC CROSSOVER NETWORK

Steep 24 dB/octave slope	Crossover frequency 20 - 5000 Hz.
Outputs are always in phase	Small 3.2" x 4.2" circuit board
Level controls on board	Optional off board level controls
Subwoofer summing option	On board RCA in/out connectors
No turn on/off transients	Fourth order constant voltage design
Low noise circuit design	Double sided circuit board

The XM9 electronic crossover network module is a fourth order constant voltage crossover design. The module provides both low-pass and high-pass outputs. The slope of both outputs is 24 dB/octave. Because of the fourth order design the high-pass and low-pass outputs of the crossover are always in phase with each other. The crossover network is implemented as a fourth order state variable filter. This filter provides both the high-pass and low-pass function simultaneously, guaranteeing a near perfect match of the high pass and low-pass responses.

One crossover network is needed for each channel of a bi-amplified system. A tri-amplified system needs two networks per channel, one to separate the high frequencies from the mid-low frequencies and another one to separate the low and mid frequencies. A quad system needs 3, and so on. The filter can also be used to drive a subwoofer, where the subwoofer is shared by the two channels of the stereo system.

The crossover frequency of the XM9 electronic crossover can easily be changed by changing the value of four resistors. These four resistors are mounted on an 8 pin DIP header plug for ease of change.

Individual level controls for the high and low pass outputs are provided with on board potentiometers. A damping control potentiometer on the circuit board allows for adjustment of the frequency response at the crossover frequency. A boost or cut of

up to 6 dB at the crossover frequency compensates for a dip or bump in the response at the crossover frequency found in some systems.

A time delay relay at the outputs of the XM9 eliminates the transients that can happen when the unit is turned on or off. Off board controls for the damping and the levels can also be used with the XM9.

The XM9 electronic crossover is built on a 3.2" X 4.2" printed circuit board of high quality glass-epoxy material. One side of the double sided circuit board acts as a ground plane for the circuit. This contributes to the very high signal quality of the XM9. A silk screen on the component side makes assembly very easy. The kit uses only high grade components: 1% metal film resistors, 1% matched polypropylene film capacitors for the filter capacitors, three dual FET input and one bipolar operational amplifier. Connectors for input, output and power make for easy assembly.

The XM9 is available as a bare board, with only the PC board and the assembly manual; as a kit, with all needed components, including a set of cable connectors; or completely assembled. The frequency module consists of an 8 pin DIP header and 4 1% Metal film resistors. The optional level/damping control potentiometer and cable assembly can be used for mounting the level control on a cabinet front panel. One of these XM9-PT is required for each low-pass, high-pass and damping control.

INSTALLATION AND USE.

The typical application for the XM9 electronic cross-over filter is to separate the high and low frequency bands in a multi-way audio system. Figure 1 shows the application in a two-way amplifier setup. The signal from the pre-amp is connected to the input of the crossover. The high pass output from the cross-over is

connected to the input of the power amplifier driving the high frequency loudspeaker (tweeter), while the low pass output is connected to the amplifier driving the low frequency speaker (woofer).

SPECIFICATIONS:

Frequency response:	DC to 100 KHz, +/- 0.2 dB
Crossover frequency:	20 Hz - 5 KHz
Insertion gain:	6dB with level controls at maximum.
Filterslope:	24 dB/Octave
Harmonic distortion at 1KHz:	less than 0.001%
Signal to Noise ratio:	better than 110dB
Input impedance:	25 KOhm
Output load capability:	2 KOhm min.
Output impedance:	50 Ohm typ
Maximum input voltage	10 V peak-peak (4 V RMS)
Power supply requirement:	dual regulated +15V and -15V @50 mA, typ

The controls and jumpers on the circuit board have the following function:

LEVEL CONTROLS:

There are two level control potentiometers on the circuit board, one for the low pass output and one for the high pass output. They

each have a range of off to +6dB. At the center position the crossover network has unity gain (0 dB).

DAMPING CONTROL:

The damping control sets the frequency response of the unit at the crossover point. The range of the damping control is from -8 dB to +6 dB, at the crossover point. This adjustment is useful for matching the frequency response of the high and low loudspeakers at the crossover point. In the center position the frequency response is totally flat, meaning that the sum of the

output voltage of the high pass and low pass channel is constant for all audio frequencies.

Table 1.			
Connector pin assignments.			
Connector	Pin #	Signal description	
- P1	1	Low pass level control, signal	
	2	Low pass level control, wiper	
	3	Low pass level control, ground	
- P2	1	-15 Volt power, 15 mA, typ.	
	2	Power ground	
	3	+15 Volt power, 15 mA, typ.	
- P3	1	Damping control, ground	
	2	Damping control, wiper	
	3	Damping control, signal	
- P4	1	High pass level control, signal	
	2	High pass level control, wiper	
	3	High pass level control, ground	
- P5	1	Subwoofer output	
	2	Ground	
	3	Subwoofer input	
- P6		Signal input, RCA jack	
- P7		High pass output, RCA jack	
- P8		Low pass output, RCA jack	

FREQUENCY CONTROL AND FREQUENCY MODULE:

The crossover frequency of the XM9 can be set by installing the appropriate frequency module. When using a subwoofer, with standard full range loudspeakers, the crossover frequency will normally be set at about 70-150 Hz. When using the crossover

network in a typical biamping setup the crossover frequency is often set at 500-2000 Hz. These frequencies depend on the loudspeakers used.

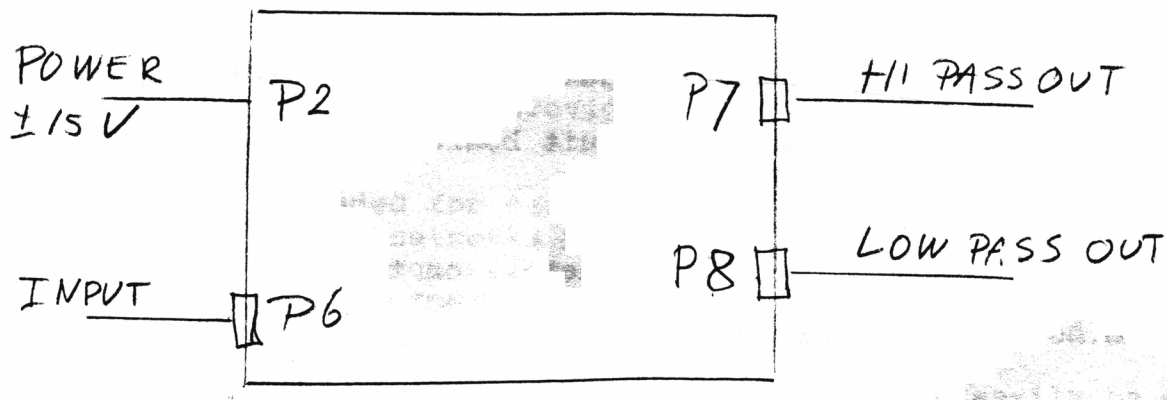

Fig 1. XM9 hookup.

Off board volume controls can be used to the high and low pass outputs and damping control of the XM9. Best results are achieved when using 10 K potentiometers with linear taper. The potentiometers should be connected with the wiper at pin 2 (center pin) and the outside leads to pins 1 and 3 of the connector. See table 1. The jumpers should be moved according to table 2. The

low pass control is connected to P1, the high pass control to P4 and the damping control to P3.

Table 2.		
Jumpers for external controls		
On	Off	Selected control
J1	J2	Low pass level control, External
J2	J1	Low pass level control, On board
J3	J4	Damping control, External
J4	J3	Damping control, On board
J5	J6	High pass level control, External
J6	J5	High pass level control, On board

Fig 10 shows some typical arrangements for 2-way, 3-way and 4-way installations. For driving long lines a line driver buffer amplifier may be needed. The XM9 outputs can drive shielded cable lines of up to about fifty feet. The XM9 is implemented with a fourth order state variable filter, (see schematic diagram). The filter is implemented with the Bi-Fet op-amp's IC1 and IC2. The virtue of

this type of filter is that it provides simultaneous high-pass and low-pass functions at the two ends of the chain of four integrators. This means that only 4 precision capacitors are needed in order to implement both fourth order functions. Both high-pass and low-pass functions will be perfectly matched, because they are derived from the same network.

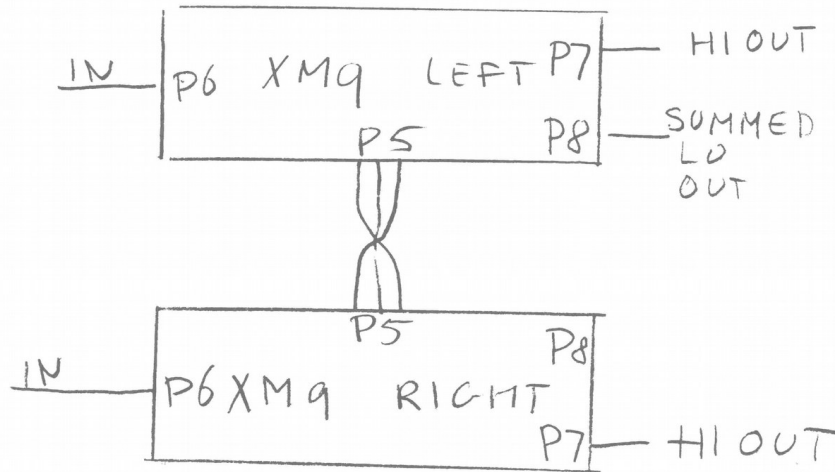

Fig 3. Example of subwoofer application.

COMMON SUBWOOFER

Two XM9 crossovers can be hooked up for driving a common subwoofer. In this case the low pass outputs of the two crossovers are summed together. Connector P5 is used for this purpose. The two crossovers are connected together with a cable

from P5 on one crossover to P5 on the other. Table 3 shows the wiring of the cable. Use a cable of not more than 30". Unshielded wire can be used. The summed output can be taken from the low pass output of either crossover board.

Table 3.		
Cable for common subwoofer		
P5 board A		P5 board B
pin 1	connected to	pin 3
pin 2	connected to	pin 2
pin 3	connected to	pin 1

POWER SUPPLY

The XM9 needs a dual +15V/-15V power supply for operation. The best choice for power supply is a regulated one. A typical power supply could be built as in fig 4. This supply can deliver 1

amp. of current; this will be sufficient for powering several crossover networks. The Marchand PS10 power supply is of similar design. It is a good choice for powering the XM9.

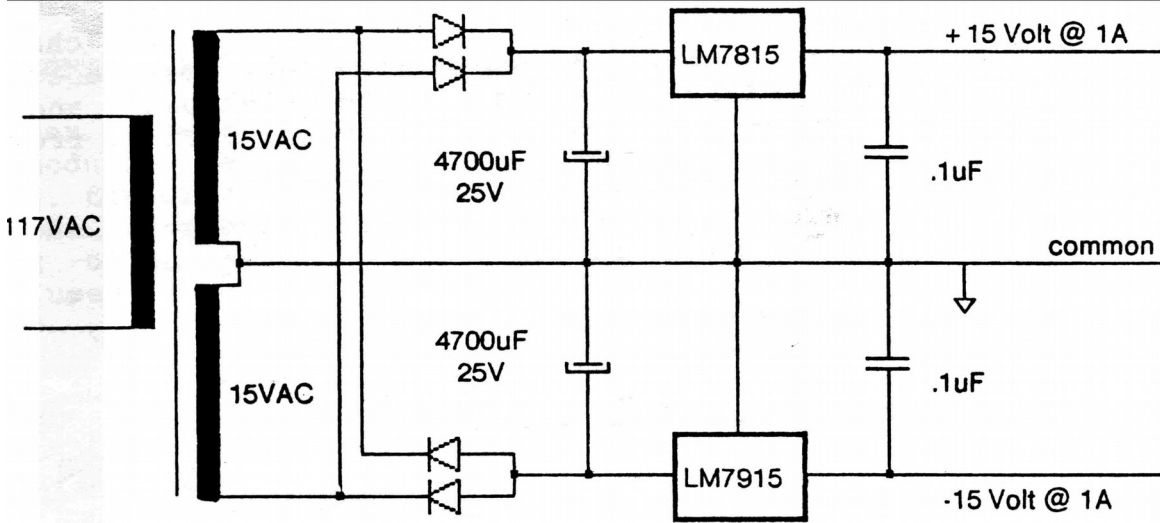

Fig 4. Simple regulated power supply for XM9.

CROSS-OVER FREQUENCY.

The cross-over frequency of the XM9 is easily changed by replacing the frequency module. This 8-pin dip header holds the 4 resistors R11-14 that determine the frequency of the cross-over

point. The four resistors should have a tolerance of 1%, and be of equal value. The value of the resistors is given by:

$$R = \frac{1}{6.283 \times F \times C}$$

F=cross-over frequency in Hz
R=resistance of R1..R4 in Ohm
C=capacitance of C1..C4 in Farad.

For a typical value of C1,C2,C3,C4 of 3300 pF, the value of R is given by

$$R = \frac{48.23}{F}$$

F=cross-over frequency in KHz
R=resistance of R1..R4 in K.

For example, a resistor value of 100K will give a cross-over frequency of 482.3 Hz. Fig 8 shows the relationship between cross-over frequency and R1 .. R4 for three different values of C1 .. C4. The value of R should not exceed 10M and should not be less than 10K. This gives a range of 4.8 Hz to 4.8 KHz for the cross-over frequency with a value of C1-C4 of 3300pF. Outside this range the value of C1-C4 should be adjusted. The minimum value of C1-C4 is 300 pF. There is no maximum allowed value.

The components used for R and C should be audio grade. Recommended are 1% Metal Film for R1-R4 and 1% matched

Polypropylene film for C1-C4. Polypropylene film capacitors match Polypropylene in performance. Other types of film capacitors are less perfect, because they have much higher absorption coefficients. Never use electrolytic capacitors for C1-C4!

On our website there is a handy calculator for finding the values of R1...R4.

See www.marchandelec.com/programs.html

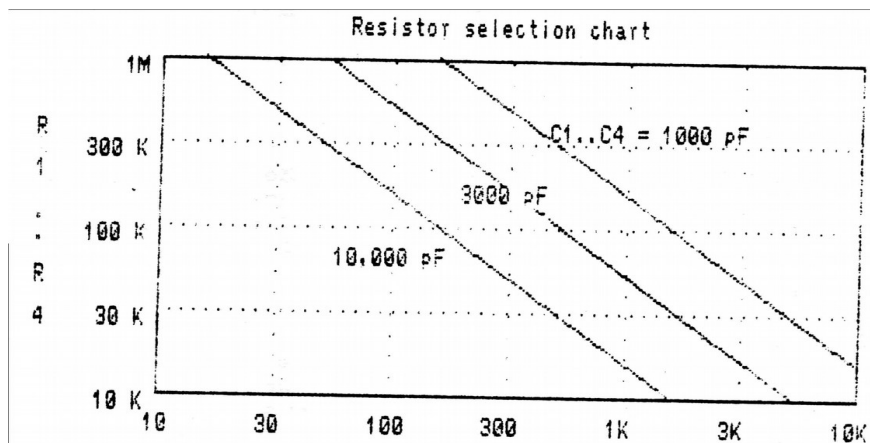

Fig 8. Relationship of crossover frequency and R1..R4.

DESCRIPTION

The XM9 implements a fourth order constant voltage low-pass and high-pass filter. The filter has a fourth order transfer function. The sum of the high-pass and low-pass output signal of the filter is thus equal to the input signal. Also, the two output signals are always in phase. This means that the output soundwaves of the loudspeakers at the crossover frequency add up in phase.

In some cases the total sound pressure at the crossover frequency may show a dip, because the sum of the output power of the loudspeakers is not unity. The XM9 has an damping factor

control that allows adjustment of the frequency response at the cross-over point. The range of the damping at the crossover point is from -4dB to +6dB. Figure 9 shows the frequency response for 3 different settings of the damping control. The high-pass function, low-pass function and sum of high and low pass are shown. The phase function is the same for all three transfer functions.

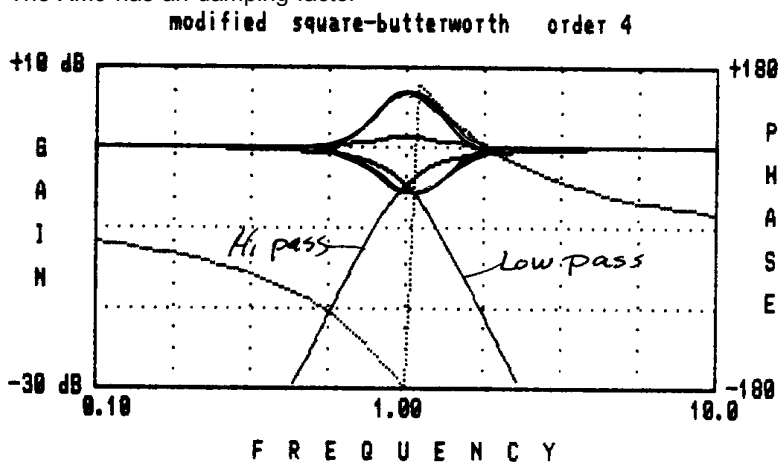

Fig 9. XM9 High-pass, Low-pass, and sum functions, with correction.

PARTS LIST

The XM9 electronic crossover kit should include the parts listed below. Please check the contents of your kit to make sure no parts are missing. All parts are available separately (consult factory).

Table 4.		
XM9, Electronic Crossover Network, parts list		
part	#	Description
R6,10,11,12		
15,16,20,22		
23,24,25,28		
29	13	24.9K, 1% Metal Film
R7	1	15.8K, 1% Metal Film
R18	1	17.4K, 1% Metal Film
R8,17	2	49.9K, 1% Metal Film
R13,14	0	not used
R19	0	not used
R26	1	5.23K, 1% Metal Film
R27	1	1M00, 1% Metal Film
R30,31	2	49.9 Ohm, 1% Metal Film
C1,2,3,4	4	3300pF, 260 WVDC, 1% Polypropylene
C5,C6	2	330 uF, 25 WVDC, Alum. Electrolytic
C7,8,9,10		
11,12,13,14	8	0.1 uF, ceramic axial capacitor
C17	1	1 uF, yellow box film capacitor
C15,16	2	100 pF, Polypropylene
IC1,2,3,4	4	OPA2134 Dual Bi-Fet Op Amp
D1,2	2	1N4937 1A diode
D3	1	1N4148 signal diode
D4	1	1N5232 5.6V zener diode
Q1	1	2N5087 or MPSA92 PNP transistor
Q2	1	PN2222 NPN transistor
RLY1	1	Relay DPDT 24V
P1...8	8	3-pos terminal block
M1,2,3,4,5	5	8 pin DIP sockets
M14	1	Circuit board, XM9-B
R1,2,3,4	4	10K-10M, 1% Metal Film (in frequency)
M15	1	8 pin DIP header (module)

MODIFICATIONS FOR BALANCED INPUT.

The XM9 can be operated with a balanced (differential) input. This is normally used with the XLR connectors. The circuit board needs to be modified by cutting the trace at point F (near the input

terminal block). The differential inputs are the terminals marked + and - at the 3-position terminal block marked INPUT. The ground is the third terminal (marked G)

MODIFICATIONS FOR FIRST, SECOND AND THIRD ORDER OPERATION

With some changes in component values the XM9 can be used as a first, second or third order filter. The changes are shown in table 5. In these modes the trimmer resistor R9 is unused and the variable damping is not functional any more. Some of the polypropylene filter capacitors are replaced with jumper wires. A jumper wire has to be installed and a trace has to be cut. The

locations for the jumpers and cuts are marked on the solder side of the circuit board. The cut has to be made at point A, near R5. Use insulated hookup wire to make a connection between point E (near R5) and point B,C or D (near C3, C2, C1). See table below. For the second and third order filter a standard Butterworth slope was chosen; for most applications this will be a good choice.

Table 5.				
Changes for lower order filter applications.				
Component	Fourth order Constant V.	First order	Second order Butterworth	Third order Butterworth
R6	24.9K, 1% MF	deleted	deleted	deleted
R7	17.4K, 1% MF	deleted	49.9K, 1% MF	24.9K, 1%MF
R8	49.9K, 1% MF	deleted	deleted	deleted
R10	24.9K, 1% MF	24.9K, 1%MF	17.4K, 1%MF	24.9K, 1%MF
R11	24.9K, 1% MF	deleted	deleted	49.9K, 1%MF
R18	17.4K, 1% MF	49.9K, 1%MF	49.9K, 1%MF	49.9K, 1%MF
R26	5.23K, 1% MF	24.9K, 1%MF	16.5K, 1%MF	12.4K, 1%MF
C2	3300 pF	Jumper wire	3300 pF	3300 pF
C3	3300 pF	Jumper wire	Jumper wire	3300 pF
C4	3300 pF	Jumper wire	Jumper wire	Jumper wire
Jumper		D to E	C to E	B to E
Cut		at E	at E	at E

MODIFICATIONS FOR FOR HIGH INPUT IMPEDANCE

The standard input impedance of the XM9 is 25 Kohm. A higher impedance can be achieved by replacing some resistors according to Table 6 below. The penalty for increasing the impedance is a decrease in signal to noise ratio. The added noise depends on the

op-amps used. For 100K impedance and OPA2134GP op-amps the noise will increase by about 2dB.

Table 6.		
Changes for high input impedance.		
Component	Standard Value 25K impedance	100K impedance
R6	24.9K, 1% MF	100K, 1% MF
R7	17.4K, 1% MF	69.8K, 1% MF
R8	49.9K, 1% MF	205K, 1% MF
R17	49.9K, 1% MF	205K, 1% MF
R18	17.4K, 1% MF	69.8K, 1%MF
R24	24.9K, 1% MF	100K, 1%MF
R25	24.9K, 1% MF	100K, 1%MF
R26	5.23K, 1% MF	20.5K, 1%MF

MODIFICATIONS FOR FOR BAFFLE STEP COMPENSATION

The baffle step effect causes a driver mounted in a cabinet to radiate more to the front of the speaker at higher frequencies. This results in a increase in frequency response at the higher frequencies. For a cabinet with a baffle size of 12" the effect starts at a frequency of about 400Hz. The total increase of intensity is 4-

6dB at the higher frequencies. A baffle step compensation circuit can be installed on the XM9 circuit board. This circuit has the effect of reducing the high frequency response. The circuit can be installed on the high-pass output or on the low-pass output.

Table 7.		
Baffle step compensation for 1000Hz (4.8" baffle).		
Component	4dB compensation	6 dB compensation
Rb	43.2K, 1% MF	24.9K, 1% MF
Cb	3000pF	4500pF

The table shows the values for Rb and Cb for 1000Hz (4.8" baffle). For a wider baffle the frequency is less. The frequency is given by $F_c = 4800/W_b$, where W_b is the width of the baffle. For frequency other than 1000 Hz the value of Cb is chosen as $C_b = 1000 * C_{bt} / F_c$, with F_c in Hz, C_{bt} is the Cb shown in the table.

In other words, choose $C_b = C_{bt} * W_b / 4.8$. Use nearest standard value available. Usually a 4 dB correction is best.

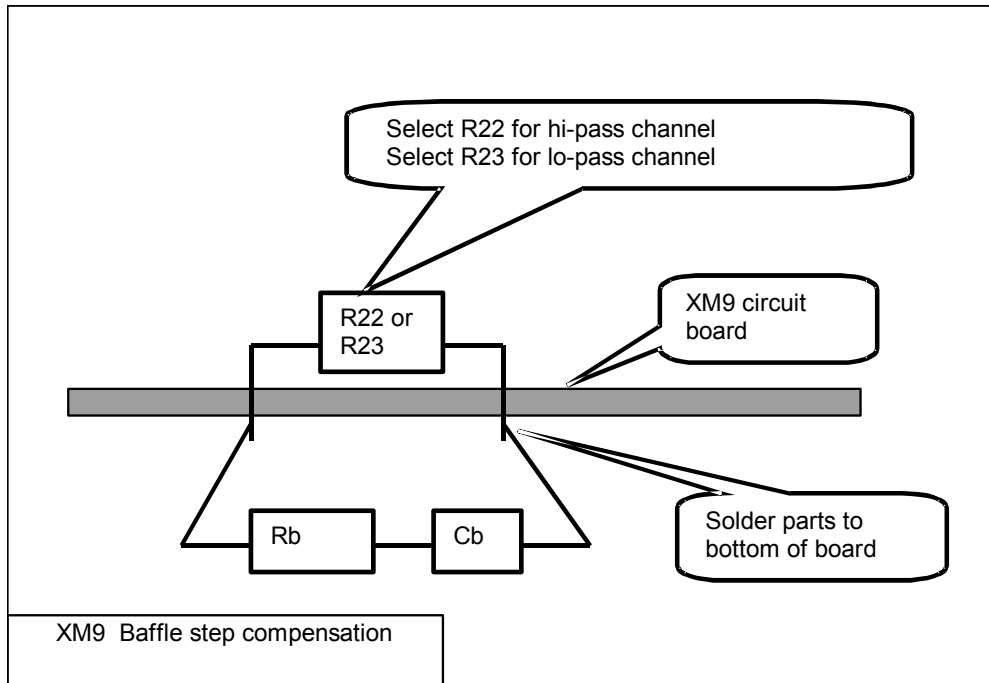

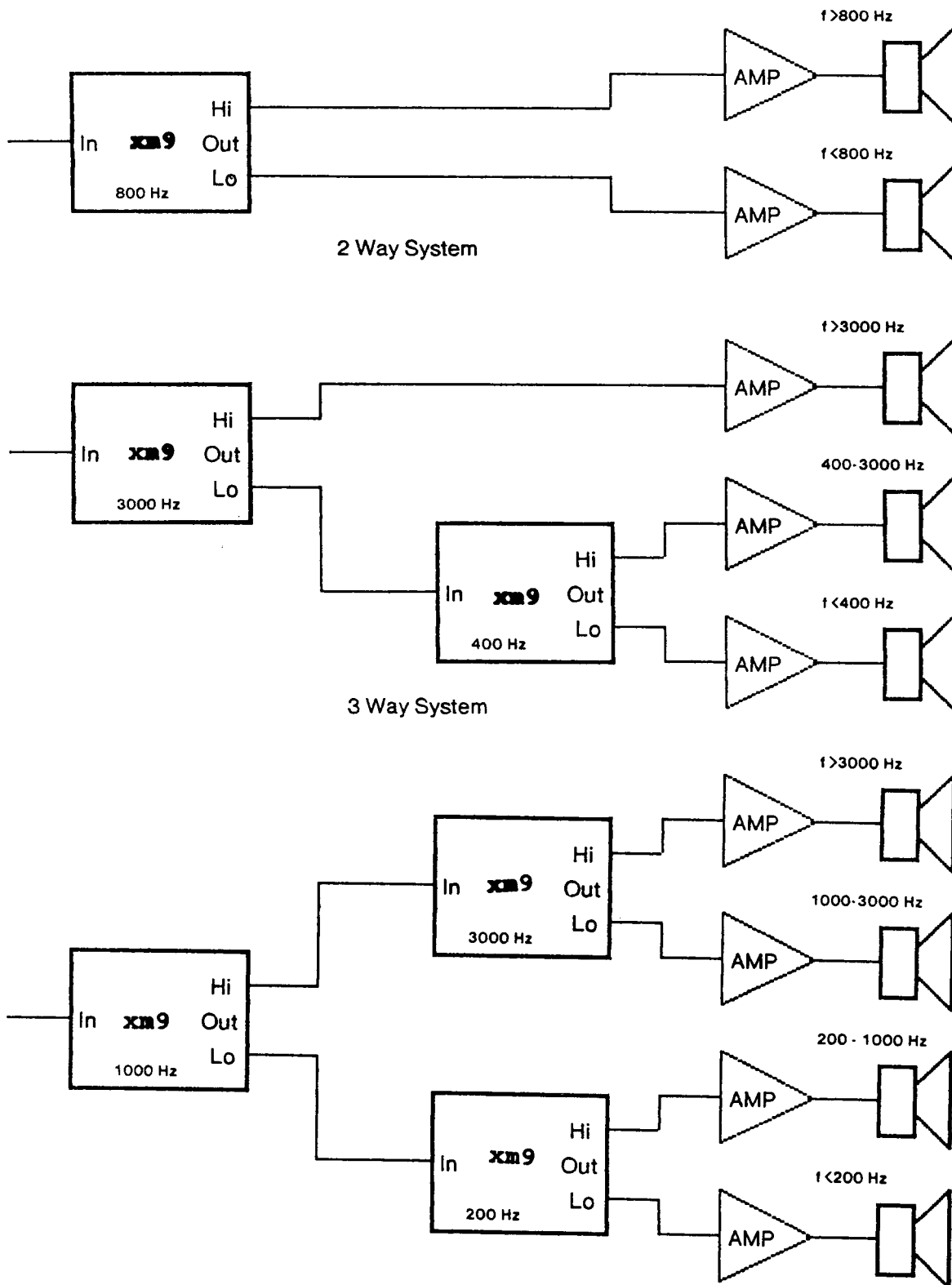

Fig 10. Typical uses of XM9 crossover network.

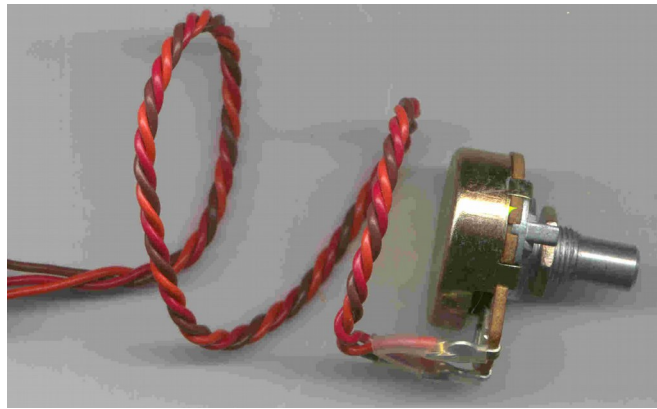
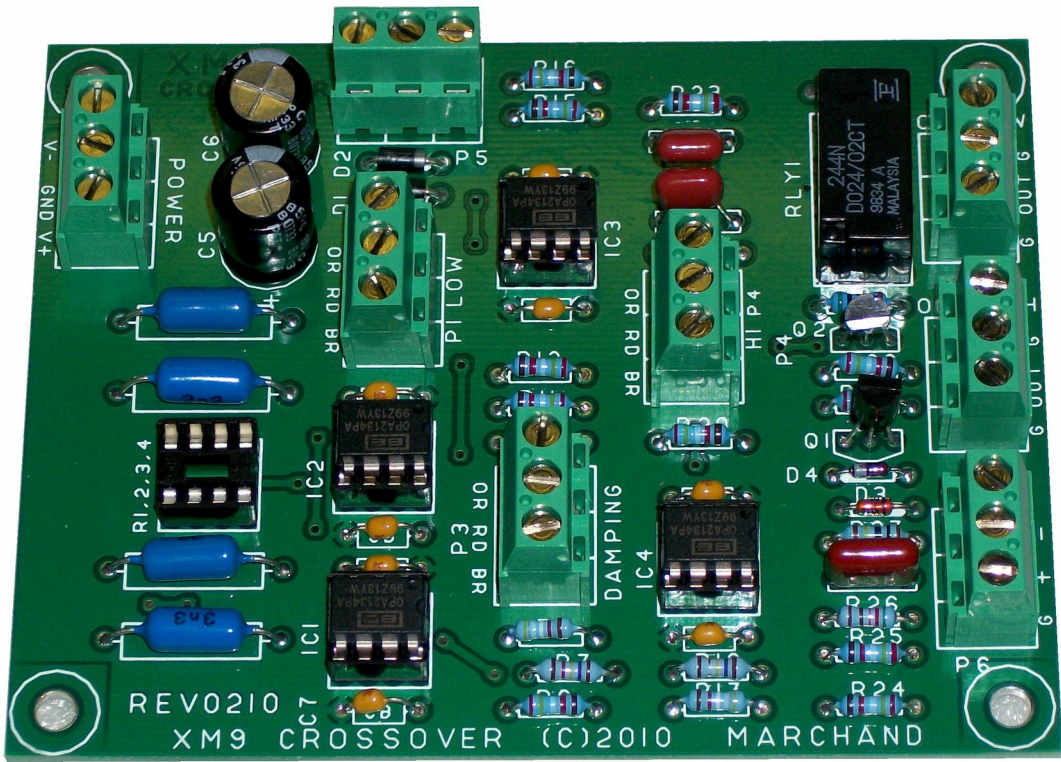

Fig 11. Top view of crossover network.

Fig 12. Potentiometer cable assembly for level and damping control.

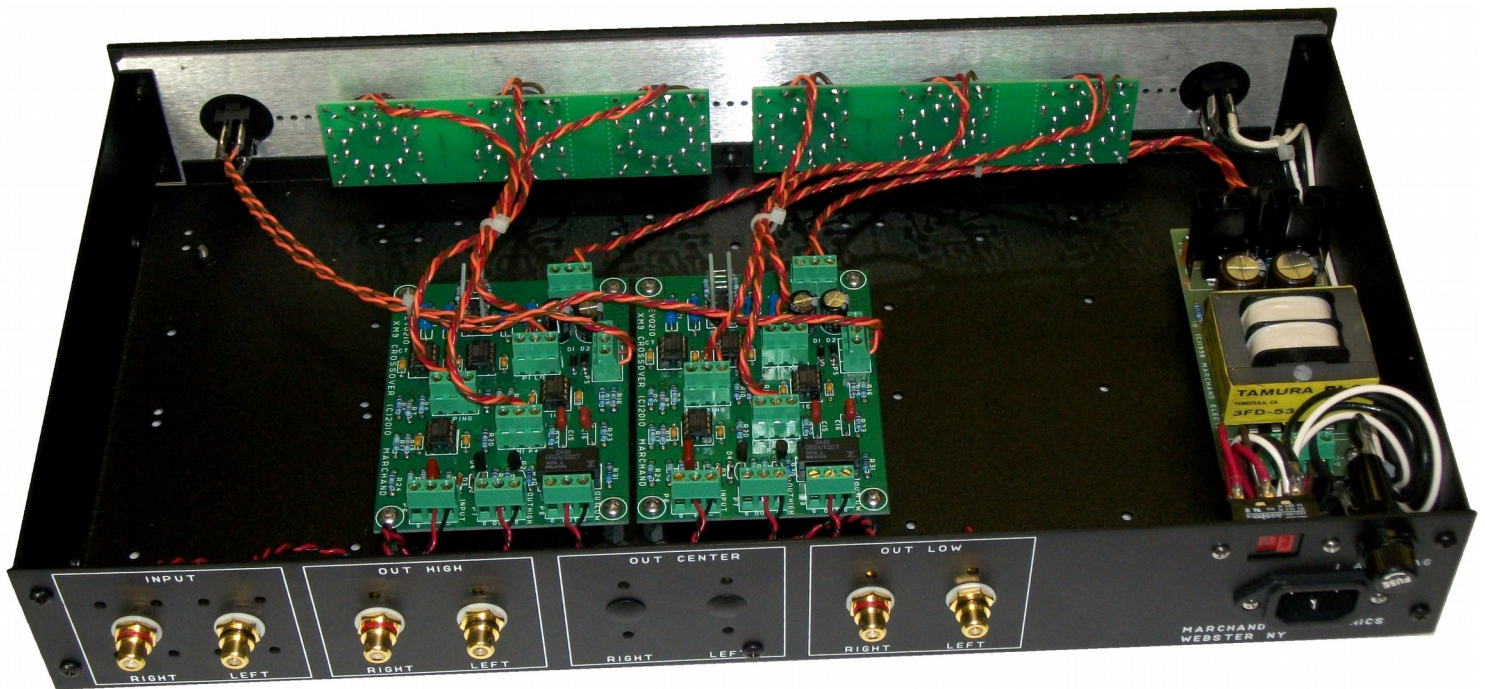
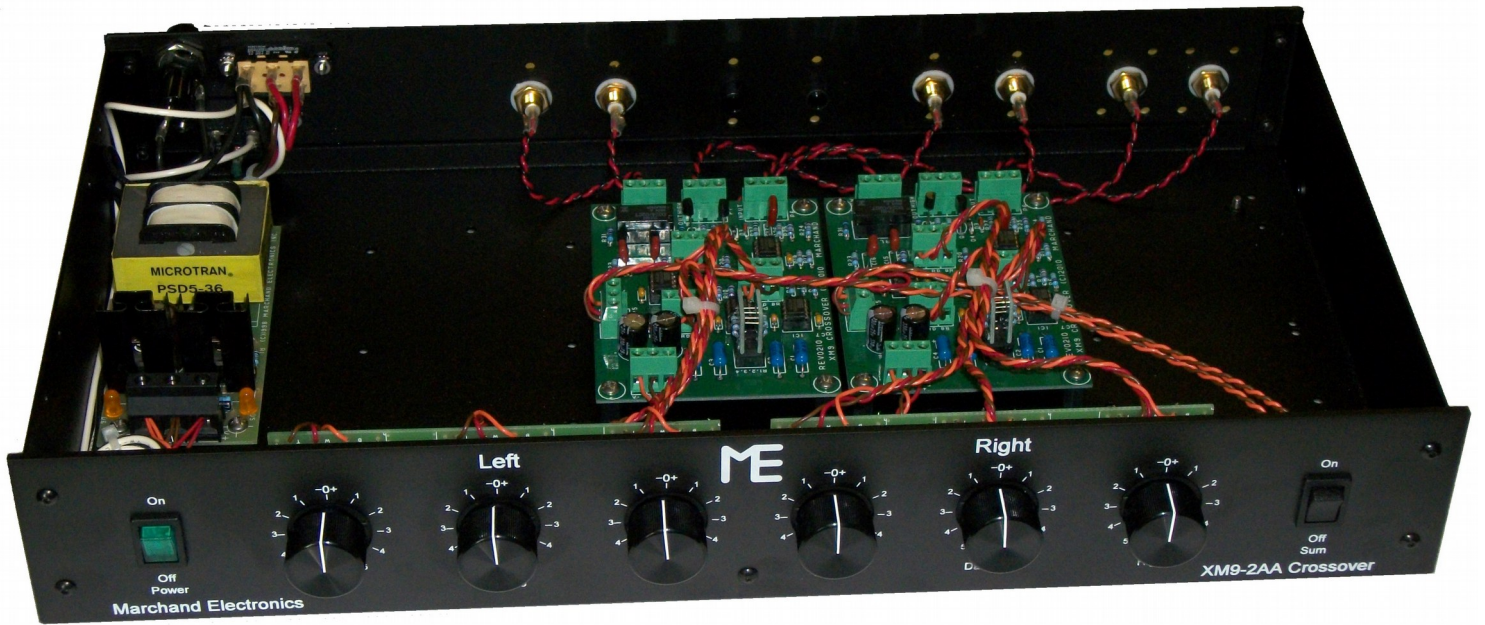
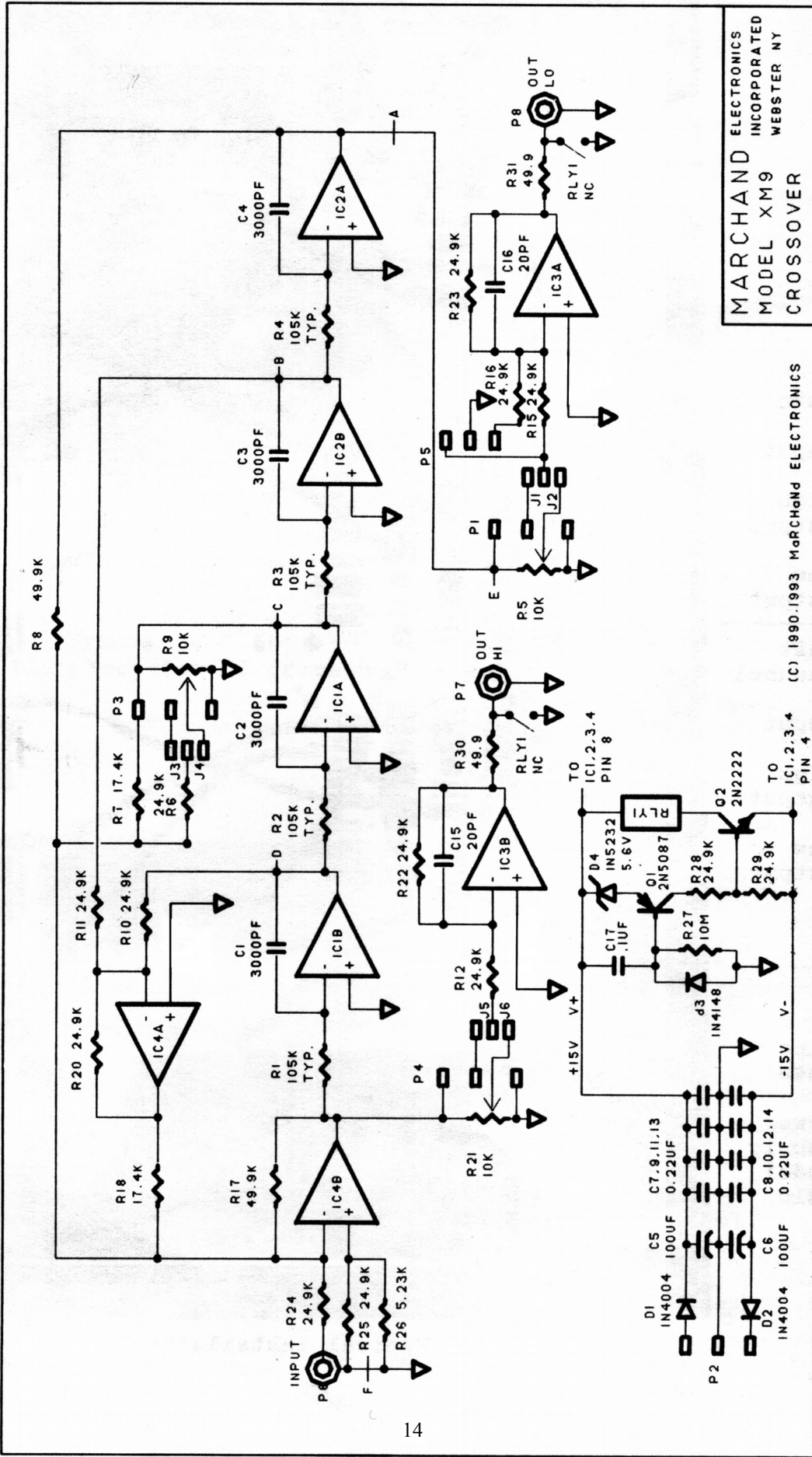

Fig 13. Typical installation in cabinet.



MARCHANT ELECTRONICS
INCORPORATED
MODEL XM9
WEBSTER NY

(C) 1990-1993 MARCHANT ELECTRONICS

TO ICI.2.3.4
PIN 4

TO ICI.2.3.4
PIN 4