

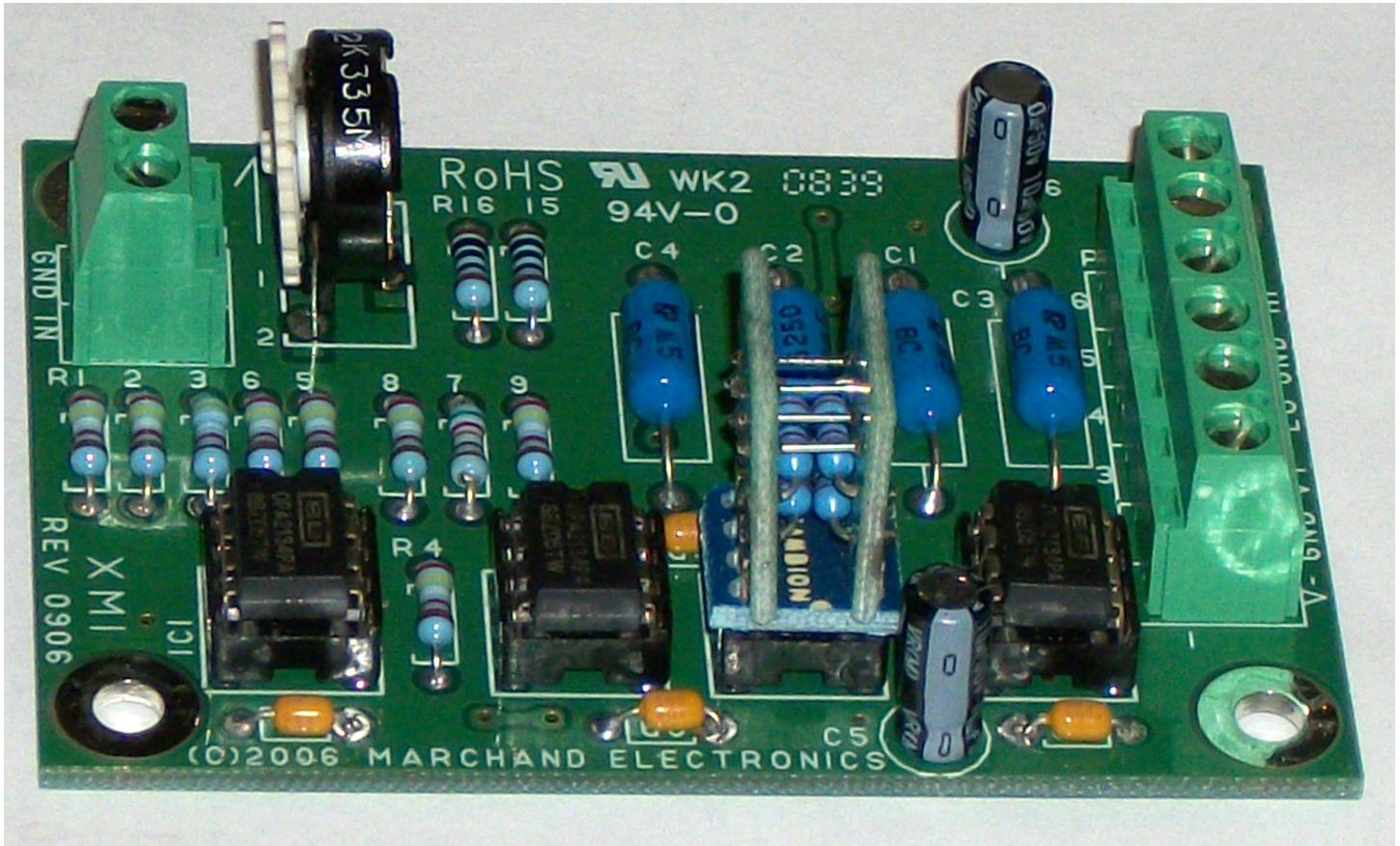

Marchand Electronics Inc.

Rochester, NY . TEL:(585) 423 0462
www.marchandelec.com

Electronic Crossover XM1



XM1 ELECTRONIC CROSSOVER NETWORK

In many high performance loudspeaker systems the individual loudspeaker drivers (woofer, mid-range and tweeter) are each driven by an individual power amplifier. The high, mid and low frequencies are separated from each other by an electronic cross over network. In a bi-amplified system there are two power amplifiers per channel, one for the low frequencies, and one for the high's. A tri-amplified system has individual power amplifiers for the low, mid and high frequencies. Quad systems have four, and so on. The advantages of electronic cross-over are many, including lower intermodulation distortion, better loudspeaker damping and more precise cross-over performance.

The XM1 electronic crossover network module is a fourth order constant voltage crossover design. The module provides both low-pass and high-pass outputs. The slope of both outputs is 24 dB/octave. Because of the fourth order design the high-pass and low-pass outputs of the crossover are always in phase with each other. The crossover network is implemented as a fourth order state variable filter. This filter provides both the high-pass and low-pass function simultaneously, guaranteeing a near perfect match of the high-pass and low-pass responses.

One crossover network is needed for each channel of a bi-amplified system. A tri-amplified system needs two networks, one to separate the high frequencies from the mid-low frequencies and another one to separate the low and mid frequencies. A quad system needs 3, and so on. The crossover can also be used to drive a subwoofer, where the subwoofer is shared by the two channels of the stereo system.

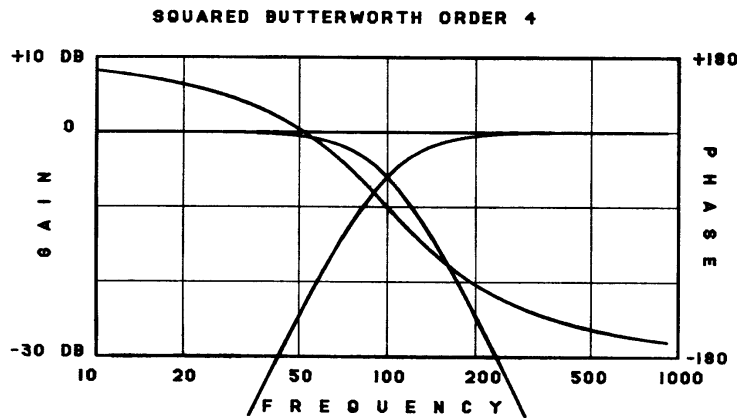

Fig 1. XM-1 High-pass, Low-pass, and sum functions.

The crossover frequency of the XM1 electronic crossover can easily be changed by changing the value of four resistors. These four resistors are mounted on an 8 pin DIP header plug for ease of change. A trimmer potentiometer on the circuit board allows for adjustment of the frequency response at the cross-over frequency. A boost and cut of up to +/- 4 dB at the cross over frequency can compensate for a dip or bump in the response at the cross-over frequency found in some systems.

The XM1 electronic crossover is built on a 2" x 3" printed circuit board of high quality glass-epoxy material. A silk screen on the component side makes assembly very easy. The kit uses only high grade components: 1% metal film resistors, 1% polypropylene film capacitors for the filter capacitors and three dual FET input operational amplifiers. Terminal blocks for input, output and power make for easy assembly.

SPECIFICATIONS.

Frequency response:	DC to 100 KHz, +/- 0.2 dB.
Cross over frequency:	20 Hz - 5 KHz.
Signal to noise ratio:	110 dB min (ref. 8VRMS signal, BW=20 KHz)
Insertion gain:	0dB (1X).
Filter slope:	24 dB/octave
Output load capability:	2K min.
Input impedance:	25 KOhm.
Output impedance:	100 Ohm.
Maximum Input voltage:	25 V p-p (8.8 V RMS).
Power supply requirement:	+15V and -15V @15 mA, typ.

DESCRIPTION

The XM1 implements a fourth-order constant voltage low-pass and high-pass filter. The filter has a Linkwitz-Riley transfer function. This is a square-butterworth transfer function, the same as two second order butterworth filters connected in series. In some cases the total sound pressure at the crossover frequency will show a dip, because the sum of the output power of the loudspeakers is not unity. The XM1 has a potentiometer that allows adjustment of the frequency response at the cross-over point. At max (CCW, direction of arrow), a 4dB peaking is realized, and at min (clockwise) there is a 4 dB dip. When the potentiometer is centered the frequency response is flat. Fig-1 shows the frequency response without adjustment. The high-pass, low-pass and sum of these are shown. The phase function is the same for all three transfer functions. Fig-2 shows the same transfer functions, but with the correction potentiometer at maximum (CCW) and at minimum (CW).

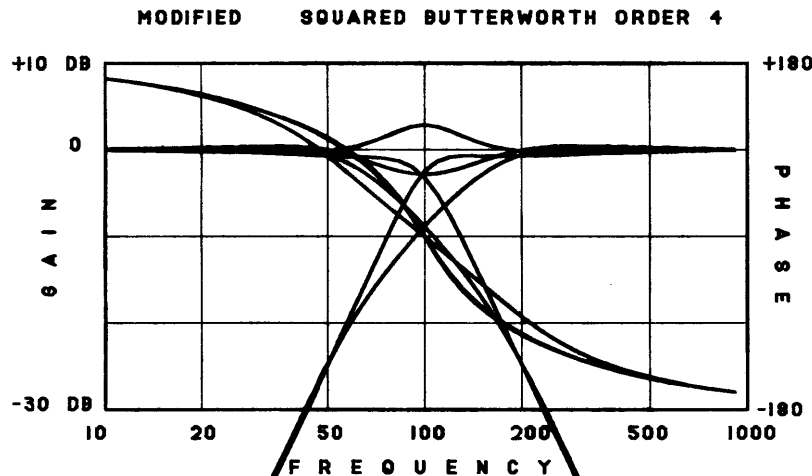

Fig 2. XM-1 High-pass, Low-pass, and sum functions, with correction.

Fig-3 shows some typical arrangements for 2-way, 3-way and 4-way installations. The XM-1 crossover network can also be used to drive a common subwoofer by adding the outputs together with a simple resistive summing network (see fig 4). For driving long lines a line driver buffer amplifier may be needed. The XM-1 outputs can drive shielded cable lines of up to fifty feet. The XM-1 is implemented with a fourth order state variable filter,(see schematic diagram). The filter is implemented with the Bi-Fet op-amp's IC1b, IC2a, IC2b, IC3a and IC3b. The great virtue of this type of filter is that it provides simultaneous high-pass and low-pass functions at the two ends of the chain of four integrators. This means that only 4 precision capacitors are needed in order to implement both fourth order functions. Also, and maybe more importantly, both high-pass and low-pass functions will be perfectly matched, because they are derived from the same network.

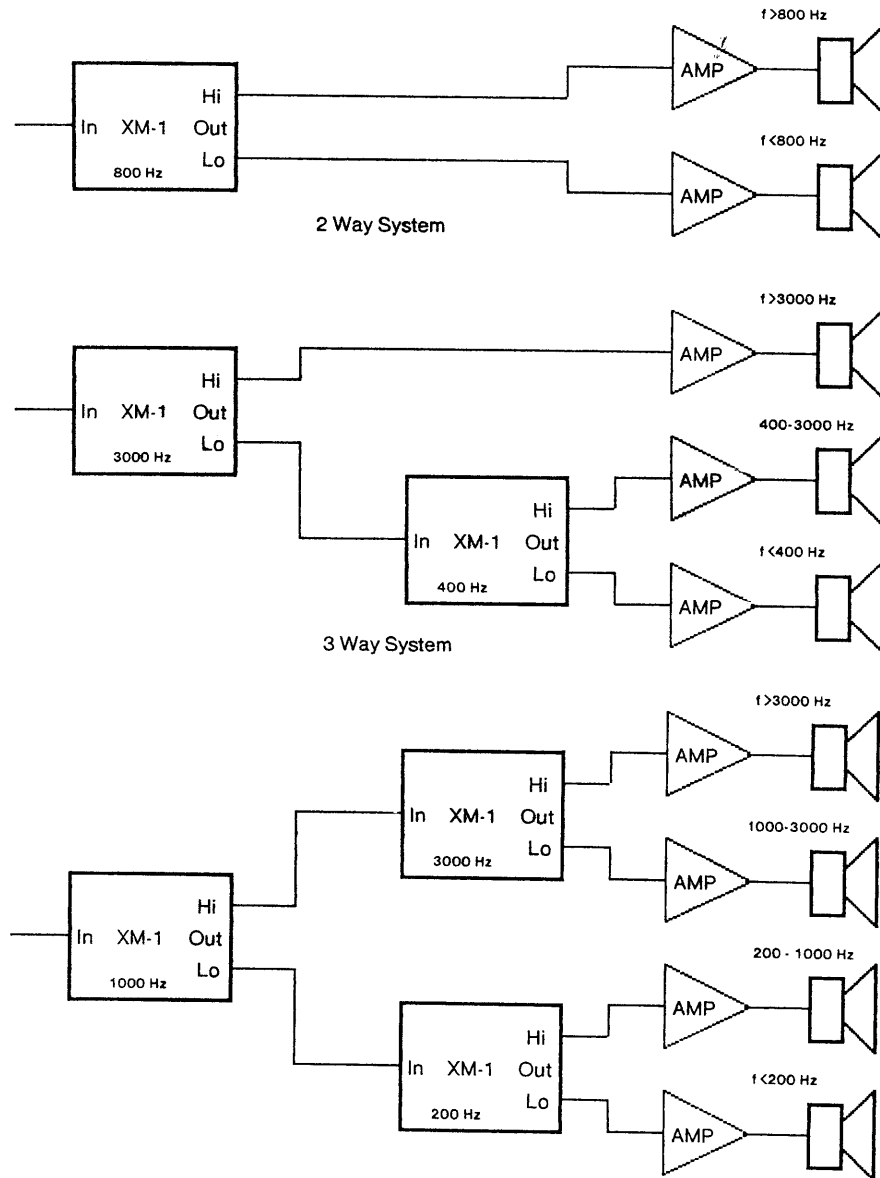
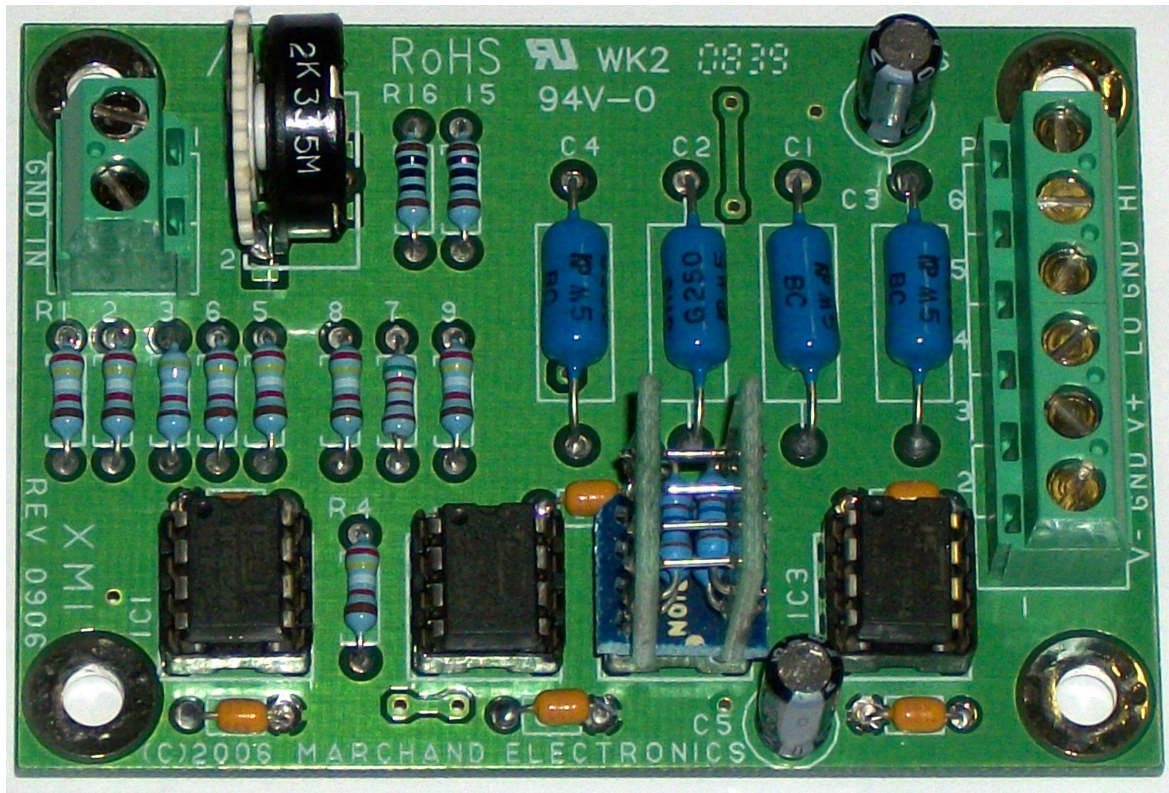

Fig 3. Typical uses of XM1 crossover network.

PARTS LIST

Table 1.		
XM-1, Electronic Crossover Network, parts list		
part	#	Description
R1,2,4,5,6,8,9	7	24.9K, 1% Metal Film
R3	1	49.9K, 1% Metal Film
R7	1	5.23K, 1% Metal Film
R10	1	2K, Trimmer potentiometer.
R15,R16	2	100 Ohm, 1% Metal Film
C1-4	4	3300pF typ., 250 WVDC, 1% Polypropylene
C5,C6	2	10 uF, 25 WVDC, Axial Alum. Electrolytic
CB	6	0.1 uF, axial ceramic
IC1,IC2,IC3	3	LF353 Dual Bi-Fet Op Amp
P1	1	2 pin terminal block
P2	1	6 pin terminal block
M1	4	8 pin DIP sockets
M5	1	2" x 3" circuit board, XM1-B
R11-14	4	100K typ., 1% Metal Film (in frequency)
M2	1	8 pin DIP header (module)



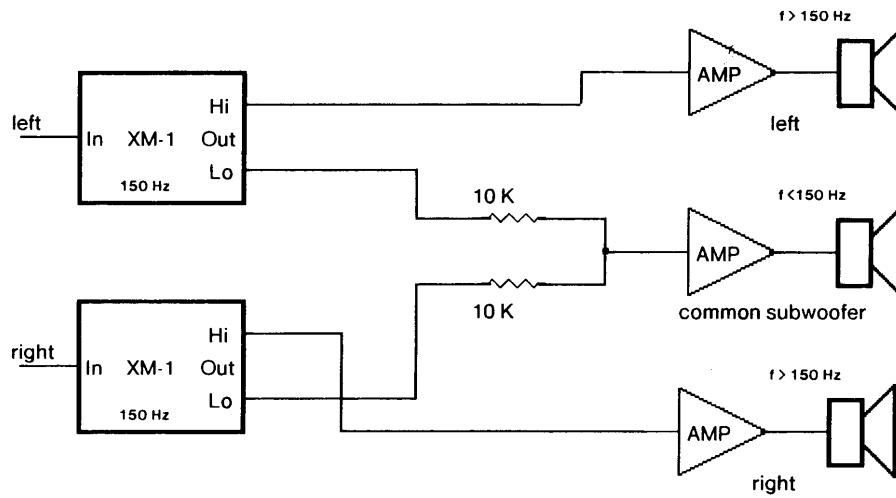

Fig 4. Example of subwoofer application.

INSTALLATION AND USE.

The typical application for the XM1 electronic cross-over filter is to separate the frequency bands in a multi-way audio system. Fig-6 shows the application in a two-way amplifier setup. The signal from the pre-amp is connected to the input of the crossover at P1. The two outputs from the cross-over from P2 are connected to the input of the power amplifiers.

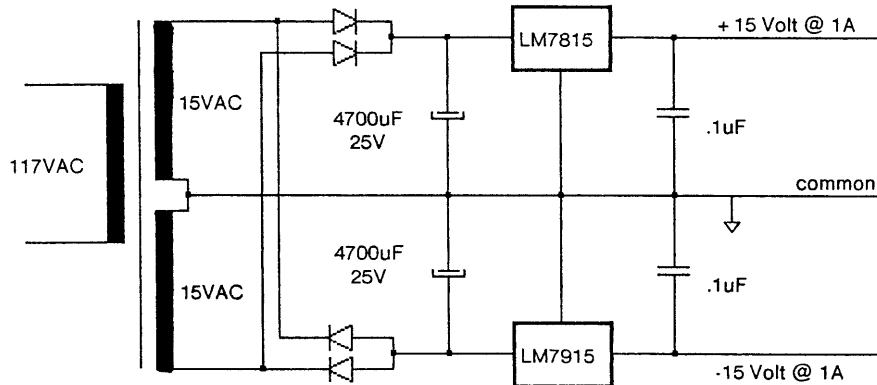

Fig 5. Simple regulated power supply for XM1.

The XM1 needs a dual +15V/-15V power supply for operation. The best choice for power supply is a regulated one. A typical power supply could be built as in fig-5. This supply can deliver 1 amp. of current; this will be sufficient for powering many crossover networks. The potentiometer control on the cross-over sets the frequency response of the filter at the cross-over frequency. With the pot in the center position the frequency response will be a flat constant voltage function. The sum of the output of both channels will equal the voltage at the input. A peaking in the sum-voltage at the crossover will result when the pot is adjusted in the direction of the arrow (CCW)(Fig 4). The maximum peaking is +4dB. This is to compensate for a possible dip in the frequency response of the loudspeakers at the crossover frequency, when driven with a constant voltage cross-over. With the pot turned fully against the direction of the arrow (min resistance, clockwise) there will be a 4 dB dip in the frequency response.

Table 2. Connector pin assignments.		
Connector	Pin #	Signal description
P1	1	Input signal ground
P1	2	Input signal
P2	1	-15 Volt power, 15 mA, typ.
P2	2	Power ground
P2	3	+15 Volt power, 15 mA, typ.
P2	4	Low-pass output
P2	5	Output signal ground
P2	6	High-pass output

Volume controls can be hooked to the high and low pass outputs of the XM1, as shown in figure 7. This allows balancing of the outputs where the power amplifiers have no volume control. Best results are achieved when using 10 K potentiometers with linear taper. When using this arrangement care should be taken not to drive cables with a length of more than about 30 feet, or the high frequencies will be attenuated. Shielded cable should be used.

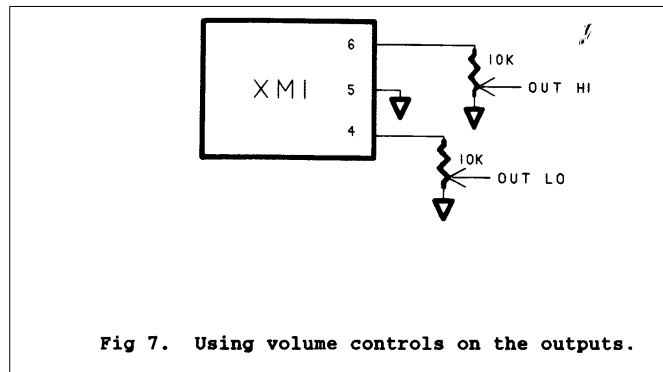
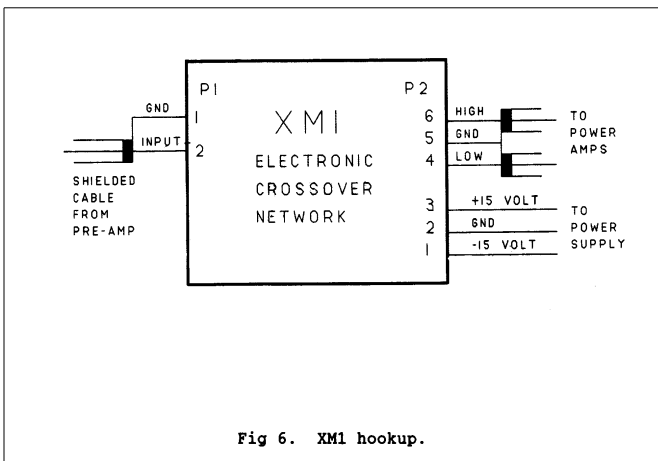
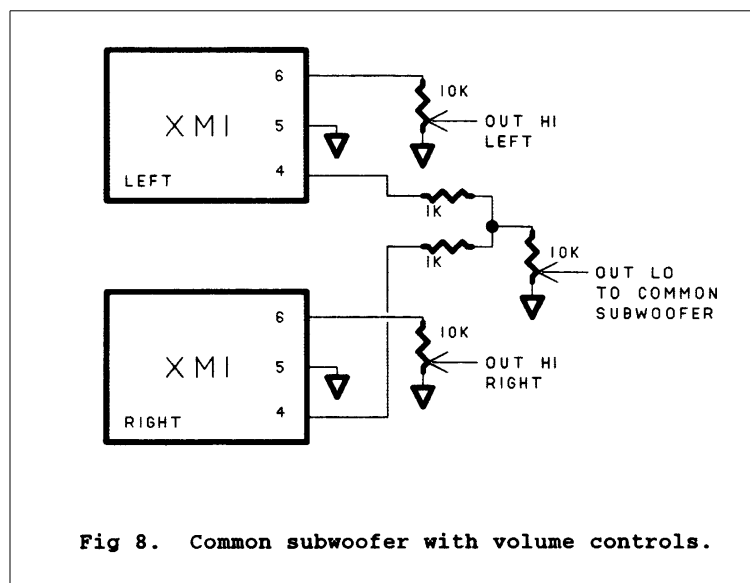
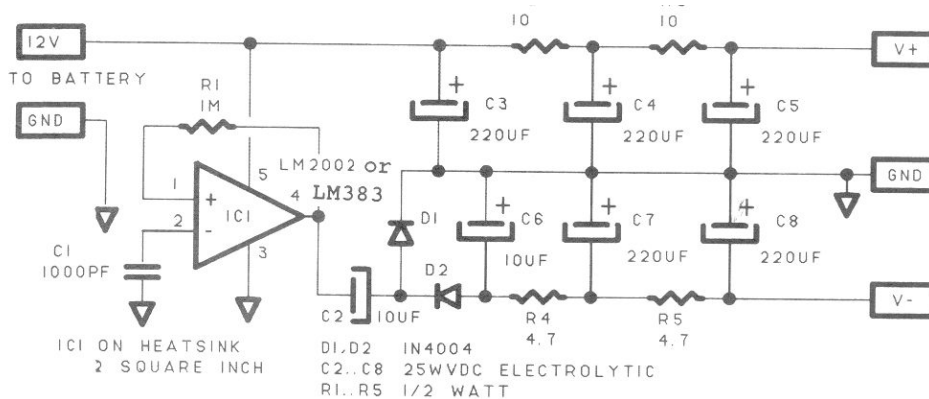
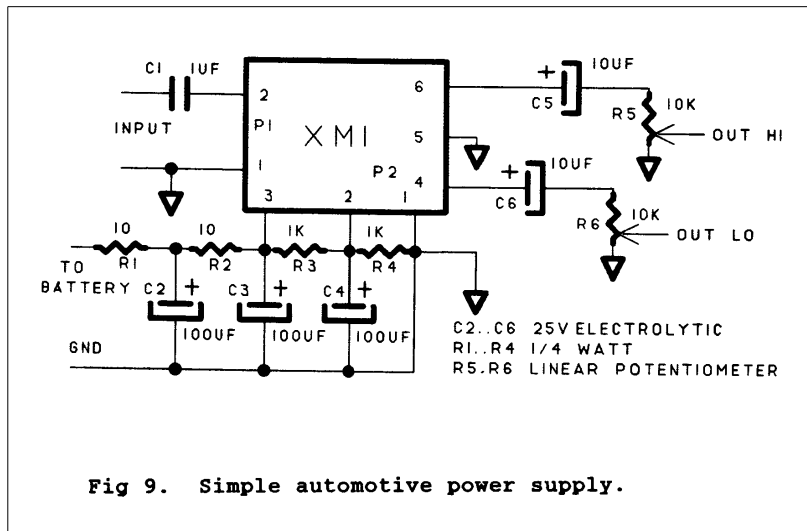

Figure 8 shows the use of volume controls with two crossovers driving a common subwoofer.



AUTOMOTIVE APPLICATIONS

The XM1 can also be used with the sound system of a car. The problem here is that most cars have a single 12 volt battery as a power source, and the XM1 requires positive and negative supply voltages. Figure 9 shows a simple solution where the 12 volt supply is used directly to drive the crossover; the ground reference is derived from the battery voltage through a simple voltage divider. This circuit works well if AC coupling of the signals is allowed and the signal levels do not exceed 2.5 volt RMS (4 volts peak). Resistors R1, R2 and capacitors C2, C3 remove noise signals from the power supply to avoid alternator whine to be passed on to the output signals. R3, R4 and C4 define the ground reference for the crossover. The input signal is AC coupled with C1, and the output signals are AC coupled with C5 and C6. Using film capacitors for C5 and C6 should be considered with high performance systems. A better solution is to use a DC to DC converter to generate the negative supply voltage from the positive battery voltage. The circuit of figure 10 uses a power amplifier IC to generate a square wave signal with a frequency of about 40 KHz. Rectification of this signal yields the negative supply voltage. No voltage regulation is used. The frequency of oscillation is set with C1. R1 provides proper bias to the input of IC1. IC1 should be mounted on a heatsink of at least 2 square inches. The diodes D1, D2 and capacitors C2, C6 make the power rectifier. R2..R5, C3, C4, C5, C7 and C8 provide power filtering in order to eliminate alternator whine, etc. from the supply. Figure 11 shows the output voltage as function of the load current, for a typical battery voltage of 13 volt. The negative power supply will be a few volt less than the positive value, but in most applications this should be no problem. With each XM1 drawing about 15 mA of supply current, this power supply is good for a load of up to 4 crossover networks.



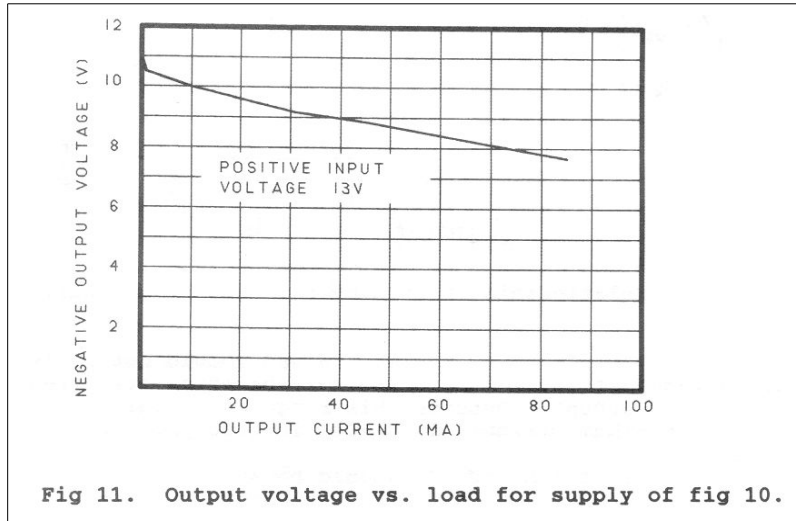

CROSS-OVER FREQUENCY.

The cross-over frequency of the XM1 is easily changed by replacing the frequency module. This 8-pin dip header holds the 4 resistors R11-14 that determine the frequency of the cross-over point. The four resistors should have a tolerance of 1%, and be of equal value. The value of the resistors is given by:

$$R = \frac{1}{6.283 \times F \times C}$$

F=cross-over frequency in Hz
R=resistance of R11..R14 in Ohm
C=capacitance of C1..C4 in Farad.

For a typical value of C1,C2,C3,C4 of 3300 pF, the value of R is given by

$$R = \frac{48.2}{F}$$

F=cross-over frequency in KHz
R=resistance of R11..R14 in K.

For example, a resistor value of 100K will give a cross-over frequency of 482 Hz. Fig 12 shows the relationship between cross-over frequency and R11 .. R14 for three different values of C1 .. C4.

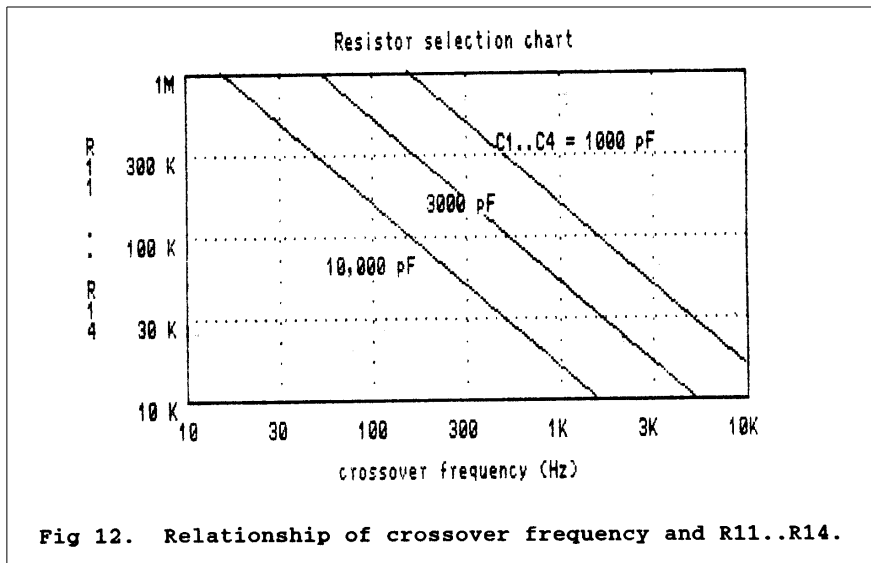

The value of R should not exceed 1M and should not be less than 10K. This gives a range of 48 Hz to 4.8 KHz for the cross-over frequency with a value of C1-C4 of 3300pF. Outside this range the value of C1-C4 should be adjusted. The minimum value of C1-C4 is 1000 pF. There is no maximum allowed value. The components used for R and C should be audio grade. Recommended are 1% Metal Film for R11-R14 and 1% matched Polypropylene film for C1-C4. Polypropylene film capacitors match Polypropylene in performance. Other types of film capacitors are less perfect, because they have much higher absorption coefficients. Never use electrolytic capacitors for C1-C4!

MODIFICATIONS FOR FIRST, SECOND AND THIRD ORDER OPERATION

With some changes in component values the XM1 can be used as a first, second or third order filter. The changes are shown in table 3. In these modes the trimmer resistor R10 is removed and replaced with a jumper, and the variable damping is not functional any more. Some of the polystyrene filter capacitors are replaced with 24.9K, 1/4 watt, 1% metal film resistors. Resistors R12, R13 and R14 are located on the frequency module header, between pins (4,5), (2,7) and (1,8) respectively. For the second and third order filter a standard Butterworth slope was chosen; for most applications this will be a good choice.

Table 3.				
Component changes for lower order filter applications.				
Component	Fourth order Constant V. 24 db/oct.	First order 6 db/oct.	Second order Butterworth 12 db/oct.	Third order Butterworth 18 db/oct.
R3	49.9K, 1% MF	24.9K, 1% MF	22.1K, 1% MF	24.9K, 1% MF
R5	24.9K, 1% MF	24.9K, 1% MF	24.9K, 1% MF	12.4K, 1% MF
R6	24.9K, 1% MF	deleted	deleted	24.9K, 1% MF
R7	5.23K, 1% MF	deleted	24.9K, 1% MF	12.4K, 1% MF
R9	24.9K, 1% MF	deleted	deleted	deleted
R10	2K trimmer	jumpered	jumpered	jumpered
R12	variable	24.9K, 1% MF	variable	variable
R13	variable	24.9K, 1% MF	24.9K, 1% MF	variable
R14	variable	24.9K, 1% MF	24.9K, 1% MF	24.9K, 1% MF
C2	3300 pF	24.9K, 1% MF	3300 pF	3300 pF
C3	3300 pF	24.9K, 1% MF	24.9K, 1% MF	3300 pF
C4	3300 pF	24.9K, 1% MF	24.9K, 1% MF	24.9K, 1% MF

GAIN ADJUSTMENT

The voltage gain of the XM1 is normally set at unity (0 dB). Other gains can be obtained by changing the value of resistor R2. The gain can be calculated from:

$$\text{GAIN} = R2/R1.$$

Table 4.		
Value of R2 for Various Gain Settings		
Gain	(dB)	R2
1	0	24.9K, 1% MF
2	6	49.9K, 1% MF
4	12	100K, 1% MF
10	20	249K, 1% MF

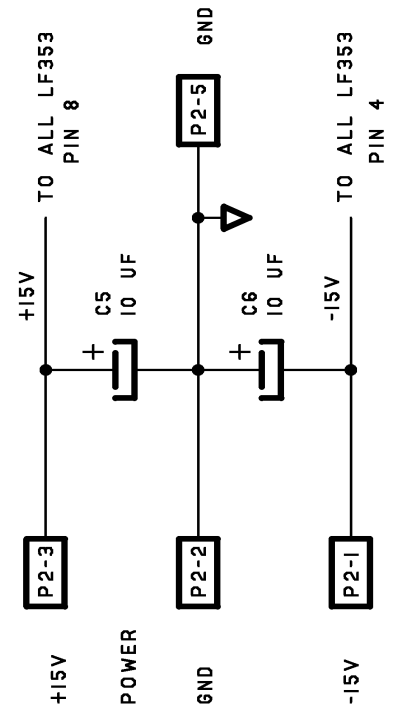
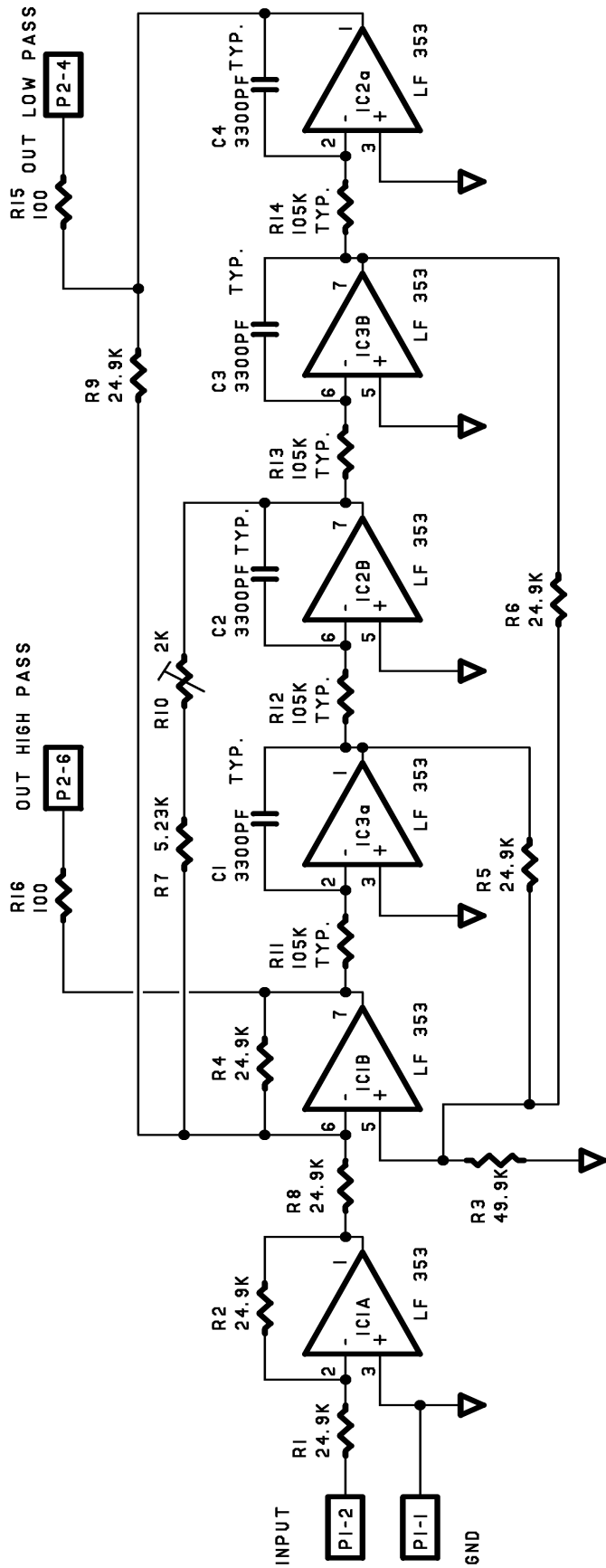

MARCHAND ELECTRONICS
 INCORPORATED
 MODEL XM1 ROCHESTER NY
 ELECTRONIC CROSSOVER

ALL FIXED RESISTORS 1% METAL FILM
 C1..C4 1% POLYPROPYLENE FILM
 (C)2003 MARCHAND ELECTRONICS